

## SIP pump protection valve officially launched

### New Schroeder Valves solution is unique on the market

Already in the middle of the year 2019, the German manufacturer Schroeder Valves announced to launch a new valve series on the pump protection market for the beginning of 2020: the SIP Valve for pressures from 140 to 250 bar. In January they presented the novelty that especially is meant to be applied in boiler feed water circuits at Combined Cycle Power Plants (CCPP) for the protection of centrifugal pumps. Yet, not exclusively, since first projects are already being carried out for pulp and paper plants and further power plants. The arguments for the SIP are diverse and cross-sectoral.

### The SIP is the answer to changing operation modes in power plants

The market challenge for an economically attractive valve with a performance of a complex high-pressure valve above 140 bar was given: because so far a low-wear, multistage pressure reduction did not work in the entire operating range of the bypass. When operating in extreme partial load below about 10% opening degree, it will eventually come to a strongly increasing pressure reduction in the section of the piston seat, which in turn can lead to cavitation and the associated excessive wear – the end of the functioning of the valve.

This situation is familiar to many plant operators, as especially in the past decade, a change in the operating mode of power plants has taken place. When in the past the operations were almost exclusively near the nominal load point – an area where the bypass of the automatic recirculation control valve is closed – today there are more and more cases with partly strongly varying load conditions down to a single-digit percentage of the rated flow that then needs to be compensated. This applies in particular to the Combined Cycle Power Plants and is also influenced by the increasing use of renewable energies.

Especially in this critical range, at flow rates just below the pump's minimum flow, it has so far hardly been possible to ensure a regular operation of the valve without damages due to cavitation. However, the SIP allows it, even in the area of the switch-point hysteresis, given sophisticated details.

With the on/off-valve type SMA as well as the SHP with multistage pressure reduction, Schroeder Valves already has had high quality solutions for high pressure applications in its portfolio for many years. Yet, with a pressure-controlled bypass and pilot valve, these products are quite cost-intensive and therefore proofed to be a real alternative only when it comes to pressures above 250 bar. With the simple lever actuation of the tried-and-trusted SSV and the multistage bypass piston of the SHP, the new SIP is an ideal combination of both solutions, offering innovation and safety at the same time.

### Wear-free in the entire operating range, from zero to 100%

The already mentioned technical innovations that make this valve so unique, are located both in the main direction of the process medium with a special design of the volume flow-controlled cone and in the

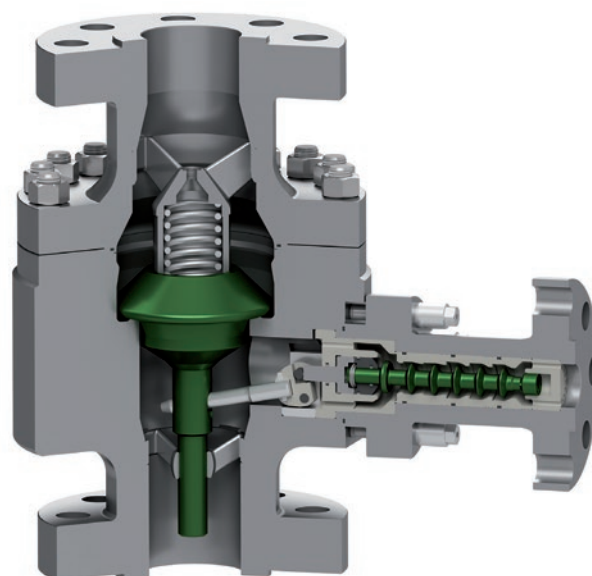
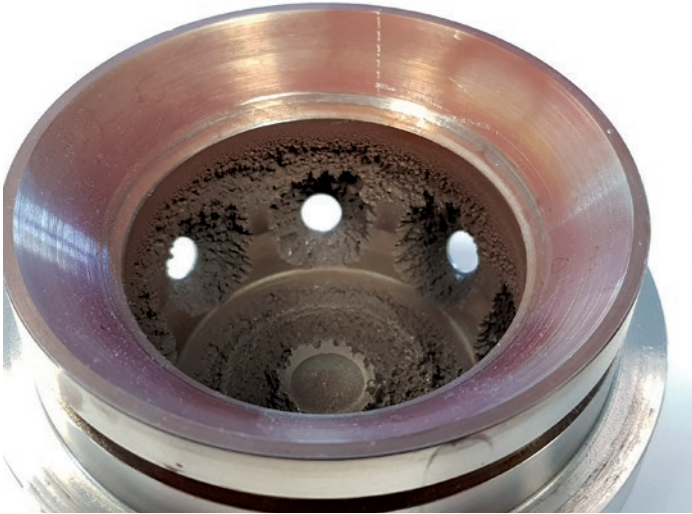

Fig. 1: SIP-valve series for pressures from 140 to 250 bar



*Fig. 2: Cavitation damage to the bypass throttle of an automatic recirculation valve*

design of the bypass, or rather the piston, and optimally protect the unit from wear and cavitation in the entire operating range, from zero to 100%. Here the Schroeder Valves solution has two decisive advantages over direct competitors in this area. And even if wear does occur, the design of the bypass still ensures fully functional operation of the valve. The bypass of the SIP also has an integrated non-return function and does not require a back-pressure regulator in the bypass pipe following the valve.

How Schroeder Valves achieves this, which details are hidden behind the development and which advantages or rather added values operators can draw from this, you may learn directly from the manufacturer or its network of sales and service agencies around the world.

The SIP is available in standard nominal diameters from DN80 (3") to DN250 (10") as well as in nominal pressures of PN250 (ASME1500) to PN400 (ASME2500) as per EN 1092 normative. Further diameters and pressures are possible. The same applies to the choice of materials, which is virtually unlimited from carbon steels to stainless steels and super duplex.

**Schroeder Valves GmbH & Co. KG**  
**Archimedesstr. 3**  
**51647 Gummersbach, Germany**  
**Phone +49 (0)2261 50116-0**  
**Fax +49 (0)2261 50116-224**  
**info@schroeder-valves.com**  
**www.schroeder-valves.com**