

Automatic Recirculation Valves

reliable
pump
protection

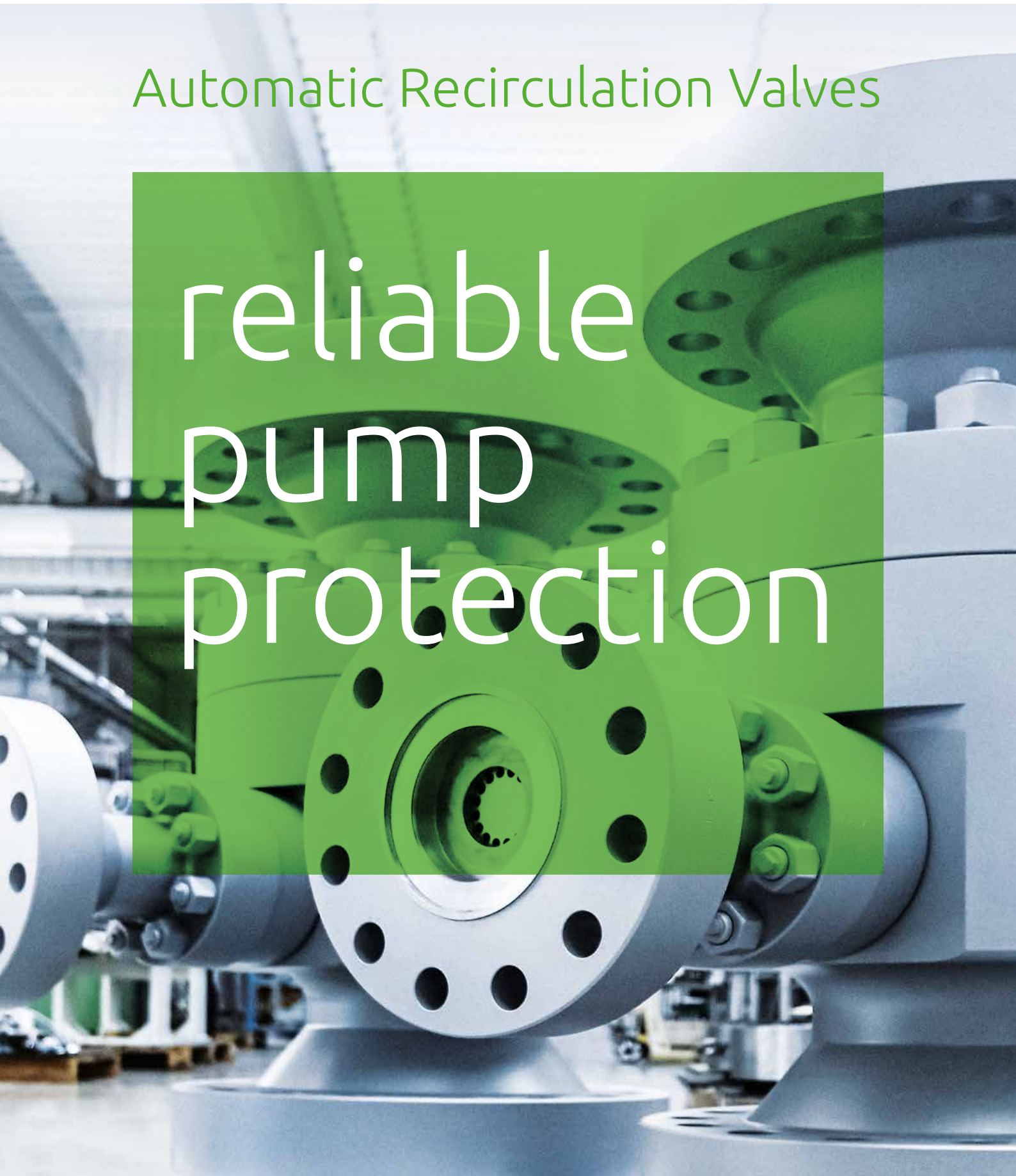
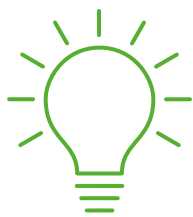



Table of content



Good to know

- The AR Valve – an essential component 4
- The Schroeder AR Valve in process 6
- Why Schroeder Valves 8
- Applications 10



Solutions

- At a glance 11

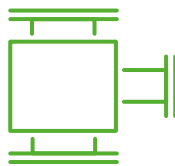

Products

- **SSV Series** – The all-rounder 12
- **SSV Series** – With control disc 16
- **SIP Series** – For intermediate pressures 18
- **SHP Series** – For high pressures 22
- **SMA Series** – High pressure ON or OFF 24
- **SML Series** – The smartline valve 26
- **SDV Series** – Back pressure device 28
- **SSD Series** – Multiport throttles 29



Technical support

- Customer Service 30

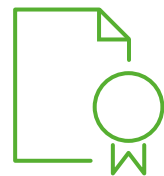

Quality

- Certifications, standards and regulations 32



ADNOC approved Vendor

The AR Valve

An essential component

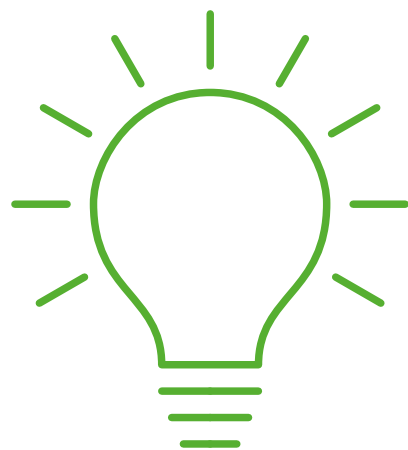

Good to know



Despite its long and cumbersome name, the Automatic Recirculation Valve (ARV) is an inconspicuous element in the centrifugal pump circuit. The AR Valve's main purpose is to ensure that a pre-determined minimum flow through a centrifugal pump is guaranteed at all times. This is important because centrifugal pumps operating below the minimum flow suffer from overheating, vibrations and cavitation and can be permanently damaged and even completely destroyed if they run dry.

Like a fuse in a power circuit – the AR Valve is essential for the safety of a plant.

Safety

Most centrifugal pumps operate with a constant speed along a fixed curve. The pumps are integrated into plants with variable discharge flows. The variable flows lead to operating ranges where process-related flowrates are below the required pump-specific minimum flow. These low flow conditions can cause severe incidents and downtime. The AR Valve ensures that the entire pump flowrate is greater than the required minimum flow-rate at all times. Thus, the pump is always protected from low flow conditions.

Operating principle

AR Valves are mounted on the discharge branch of the pump or in the discharge line right after the pump. The bypass branch of the valve is connected to the bypass line. The valve is solely flow-controlled. In start-up conditions with closed main line, the valve will allow the minimum flow through the bypass. As the discharge line is open, the valve will modulate flow between the process and the bypass branch.

As soon as the process demand exceeds the minimum flow, the bypass will fully close and all flow through the valve is sent to process. If the actual process flowrate falls below the required minimum flow, the valve automatically opens the bypass and the determined flowrate recirculates through the bypass line to a tank or vessel.

Advantages

- combination of main line check valve and automatic bypass flow control
- perfect backflow preventer in main direction
- ideal guard against damages from overheating and cavitation
- very reliable, extremely low-maintenance and particularly durable
- reduces downtime and increases system efficiency
- no auxiliary power supply or measurement technology required
- guaranteed lower system and operating costs
- also suitable for variable rpm pumps

The Schroeder Automatic Recirculation

Exemplary Configuration

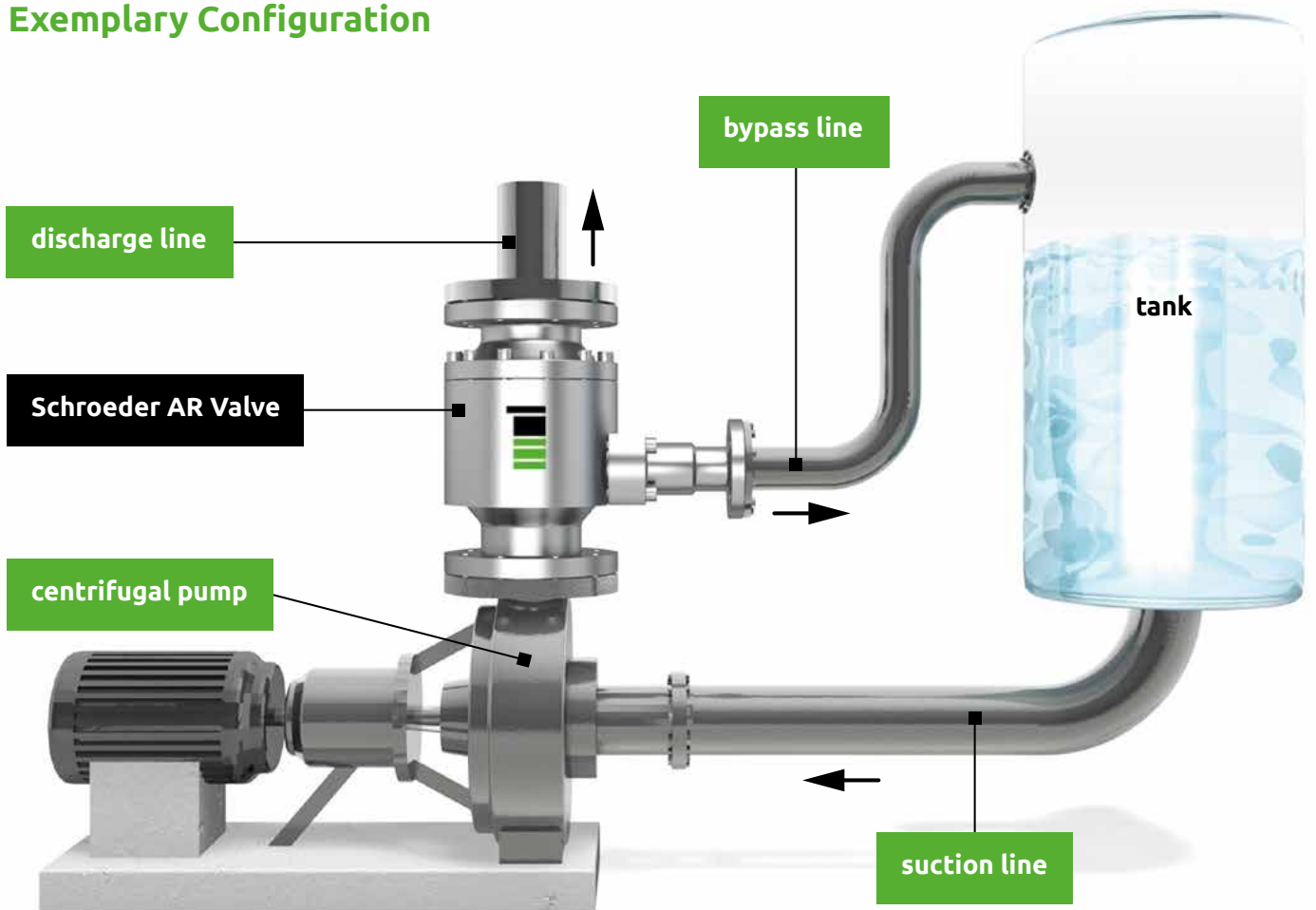

Valve in the process



Pump station at a snow-making facility in the Zillertal Alps, Austria

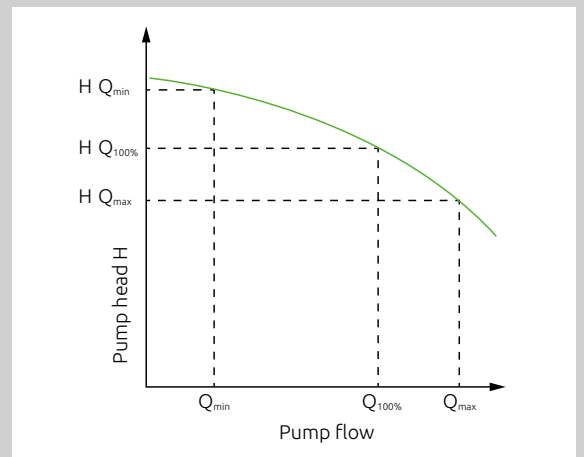
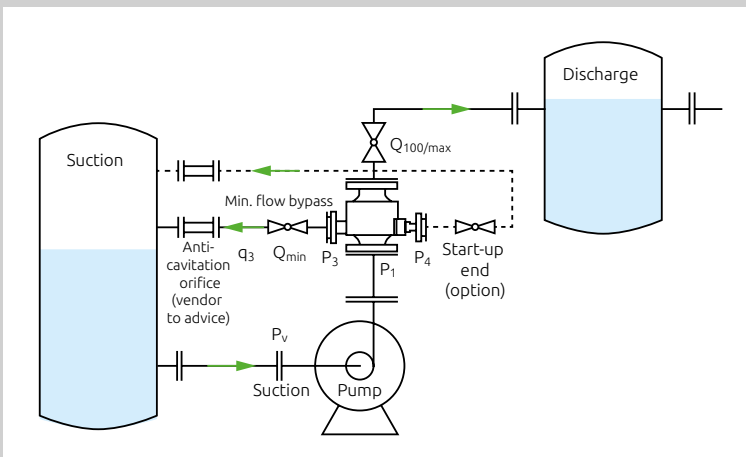

Your Benefits

Why Schroeder Valves

With Schroeder Valves you have chosen a family-owned, internationally operating company with a tradition that dates back more than 125 years. Though our high-quality valves protect pumps around the globe, every single one of them is tailor-made for the individual demand of each customer application.

The safety of your pumps, your plant and of the environment is of the utmost importance to us. Since our products must meet the highest safety requirements and are often used in the toughest conditions, the quality of our products and services are our top priority. To ensure superior quality and reliability, we have developed a stringent quality control procedure at our unique test facility. Each of our valves leaves our plant only after passing a 100% functionality test, of which you can obtain a test certificate and even witness the test in person.

But it is not only all about pumps and valves. It is also about personal availability and cooperation. We are here to listen to your requirements, to understand your needs and to convert them into pragmatic solutions. Your knowledge about your process, combined with our know-how in AR Valves, results in a perfect match for pump protection and efficiency.

reliable pump protection



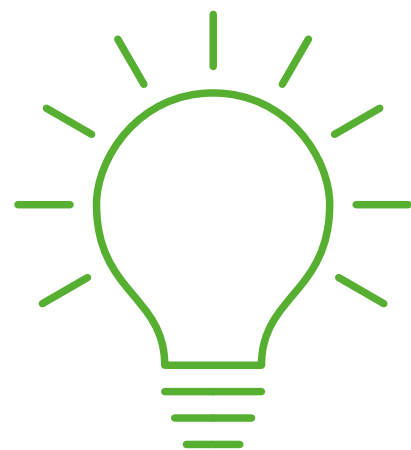

Good to know

Applications

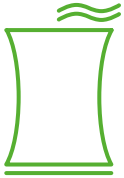

Power Plants

- boiler feed water cycle
- condensate cycle



Chemical Industry

- process chemicals
- liquid gases



Petrochemical Industry

- hydrocarbons
- liquid gases



Offshore / Seawater

- fire extinguishing
- water injection



Renewable Energies

- solar plants
- hydrogen generation



Ship loading / Marine

- feed water cycles
- firefighting
- cargo pump systems

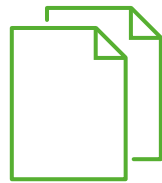

Paper Industry

- boiler feed water cycle

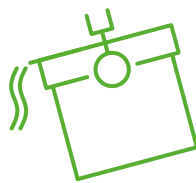

Steel mills

- descaling

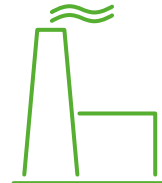

Industry

- snow blowers
- industrial heating systems
- test benches

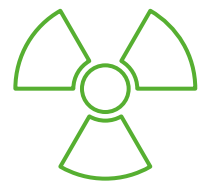

Nuclear Power Plants

- secondary feed water cycle
- primary circuit (auxiliary systems)



LNG

- liquefied natural gas



Combined Cycle Power Plants (CCPP)

- boiler feed water cycle



Carbon Capture and Storage

- diverse processes



Hydrogen

- diverse processes

At a glance

Solutions

Standard Pressure Range of Schroeder AR Valves

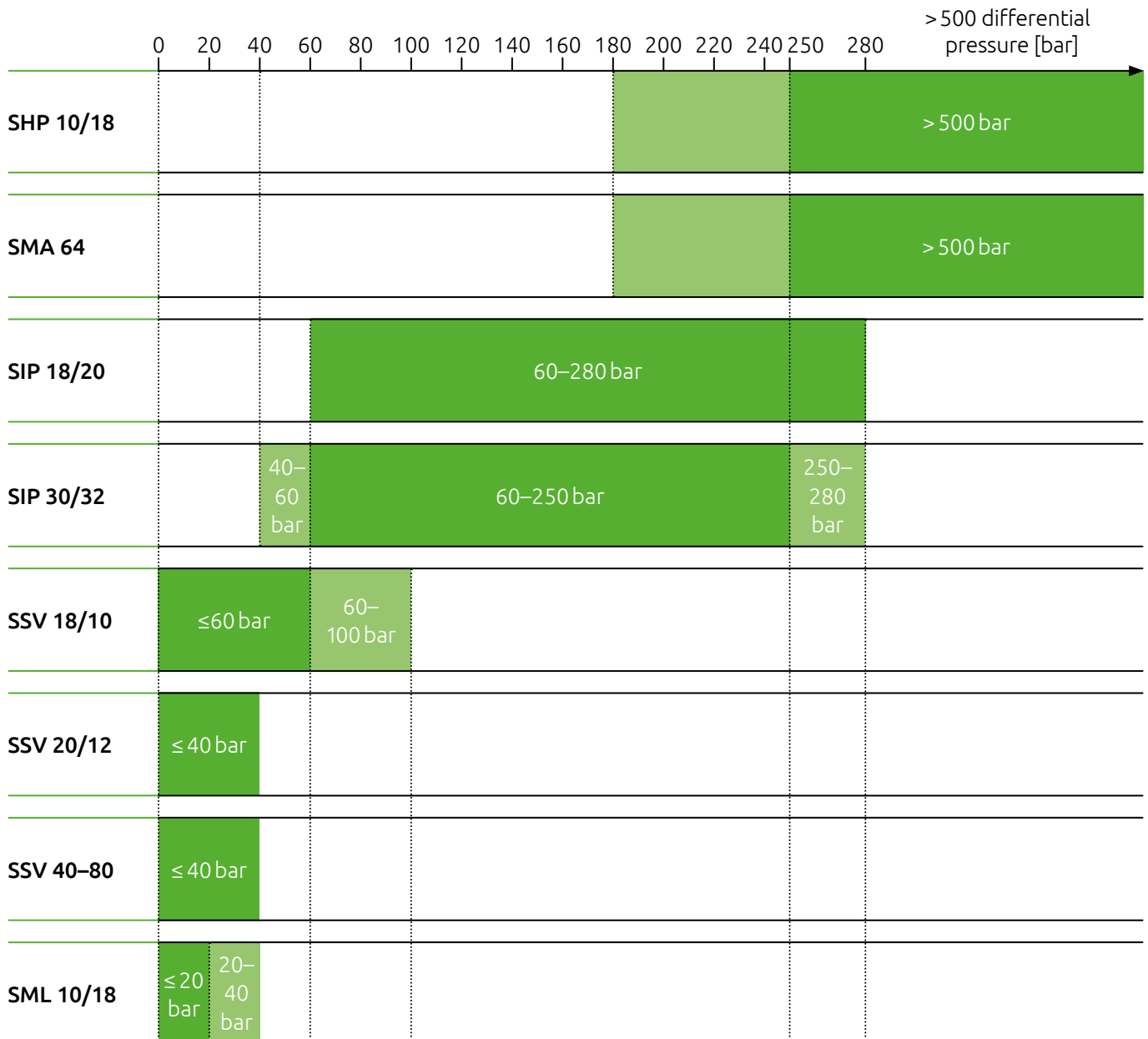

■ possible range ■ preferential range

Valve body materials

- carbon steel
- stainless steel
- duplex and super duplex
- alloys

Valve internal materials

- stainless steel
- duplex and super duplex
- alloys

Standard sizes

- DN32-350 / 1,5"-14"
- up to 24" realized (others upon request)

Standard pressure classes

- PN10-400
- ASME 150-2500 (others upon request)

SSV Series

The all-rounder

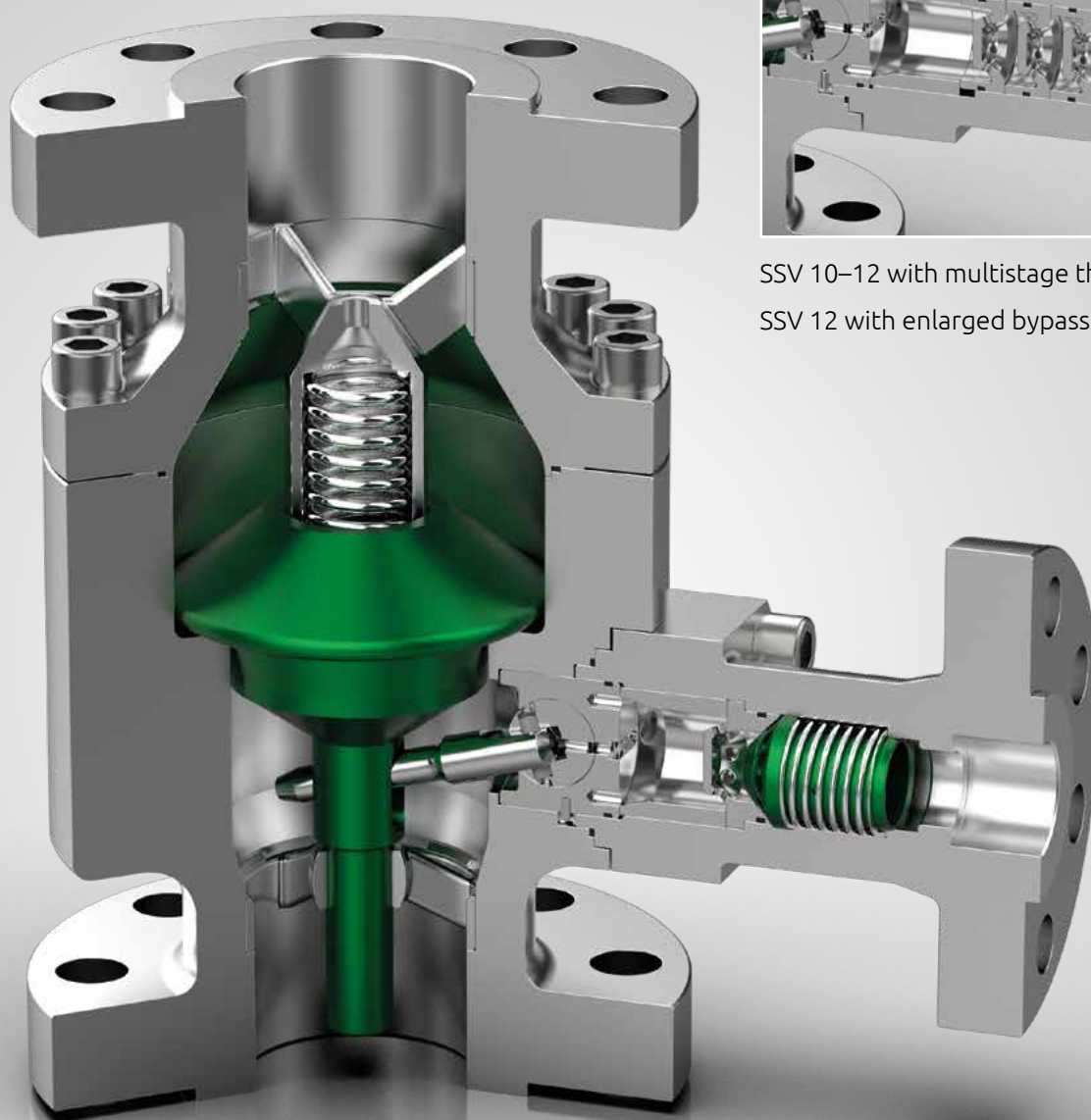

SSV 10–12 with multistage throttles
SSV 12 with enlarged bypass

SSV 18–20 with non-return valve in the bypass
SSV 20 with enlarged bypass

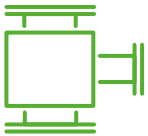

The AR Valve of our SSV series 18 and 20 (see graphic on page 14–15 for details) is a reliable device that automatically protects centrifugal pumps against wear, total loss and damage that can result from running dry, from cavitation or from operating under low-load conditions, generally suitable for pressures up to 100 bar (SSV 18). As soon as the main flow falls below the required minimum flow, the valve opens its bypass to the extent that the required pump minimum flow is discharged even if the main flow is zero. The pressure in the bypass is reduced via an integrated throttle line with a bypass non-return valve. The SSV series 10 and 12 work with pressure reduction in the bypass by throttles only.

Scope

The SSV series valves are suitable for all kind of liquid fluids, for example in

- boiler feed water and condensate cycles of fossil and nuclear power plants as well as
- combined cycle power plants
- petrochemical and chemical industries
- offshore applications
- the production of renewable energies
- the paper industry
- steel mills
- fire extinguishing systems
- LNG applications
- snow blowers and other industries



Operating principle

The AR Valve is flow-controlled, i.e. the non-return cone that controls the bypass via a lever, is raised solely by the main flow and into a determined position. Increasing main flow lifts, decreasing main flow lowers the cone position. The cone reaches its top end position at operation flow. Via the lever, the non-return cone actuates the rotary valve in the bypass. When the cone is on its seat, the bypass valve is fully open. By opening the discharge line, the increasing main flow lifts the cone and the bypass is closed simultaneously. The valve is operating in a modulating way, i.e. it allows just as much liquid to flow through the bypass as is necessary to supplement the required minimum flow rate of the pump. The addition of main and bypass flow rate is always the required pump minimum flow. As soon as the main flow rate exceeds the pump minimum flow, the bypass is closed. Vice versa, the bypass is opened again when the main flow falls below the minimum flow.

Advantages at a glance

- highly flexible application range
 - experienced, robust design
-

The all-rounder

SSV 18 Dimensional drawing with optional DN4 branch:
main spare- and wear parts.

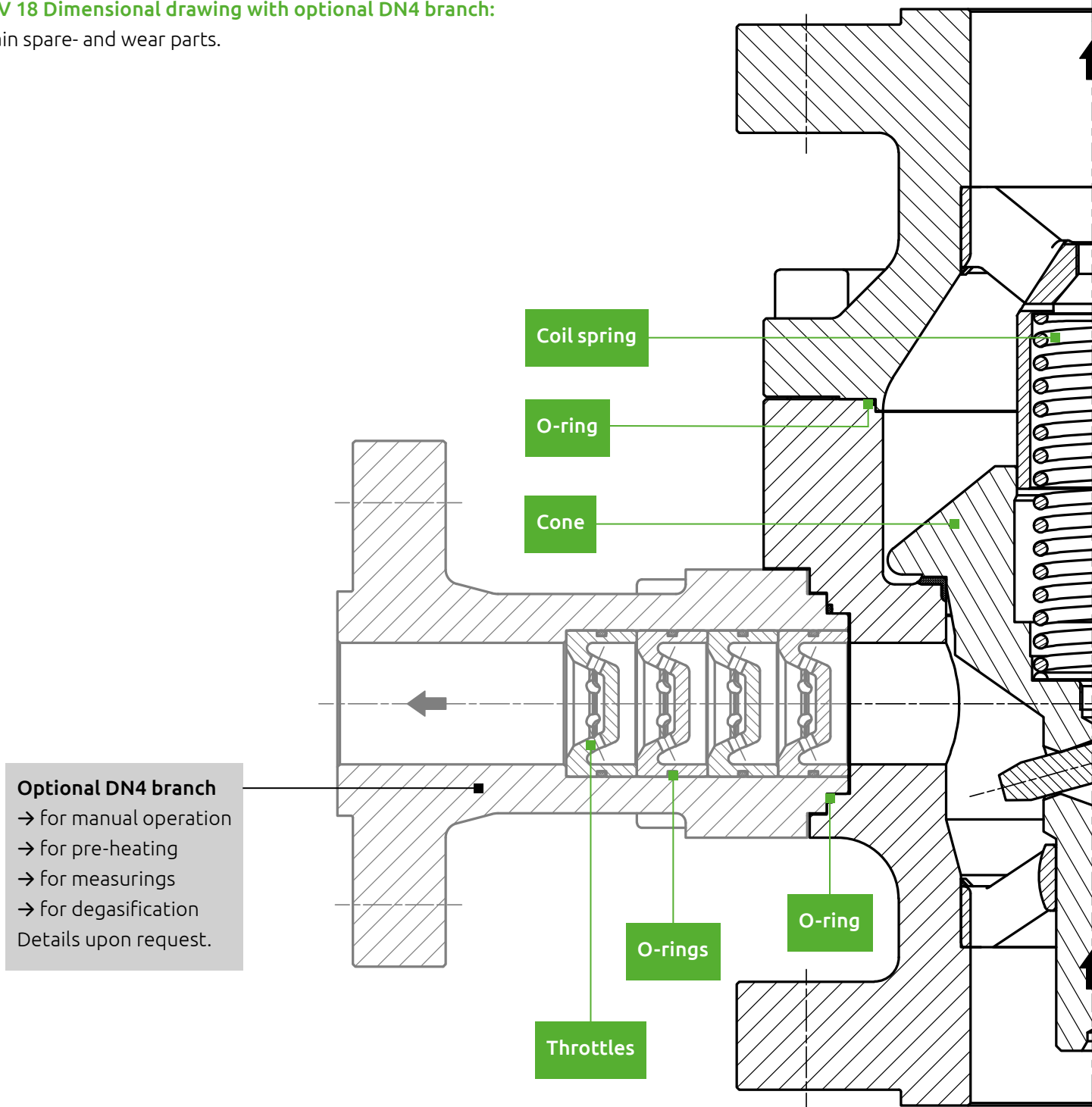

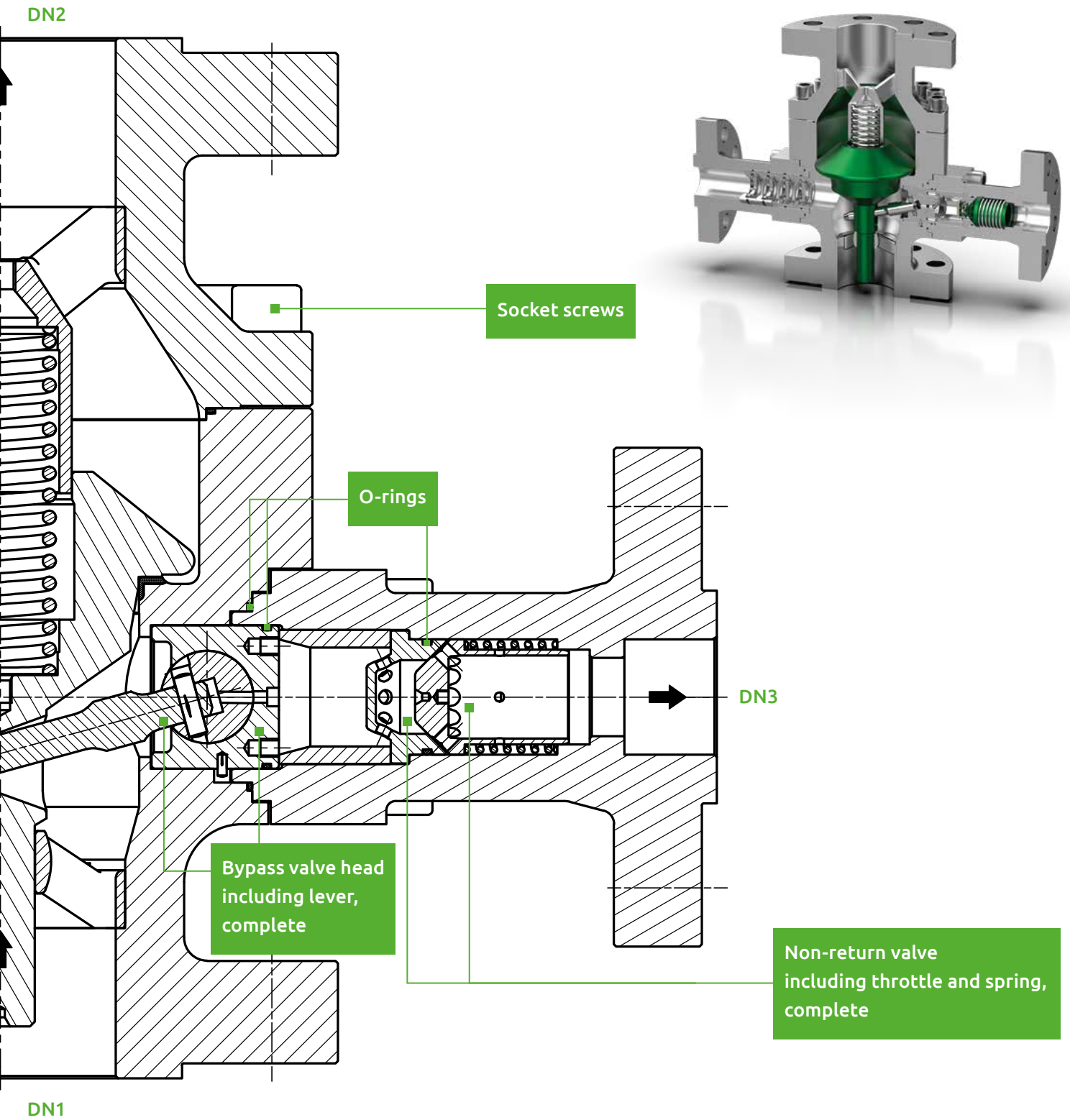

SSV Series

With control disc

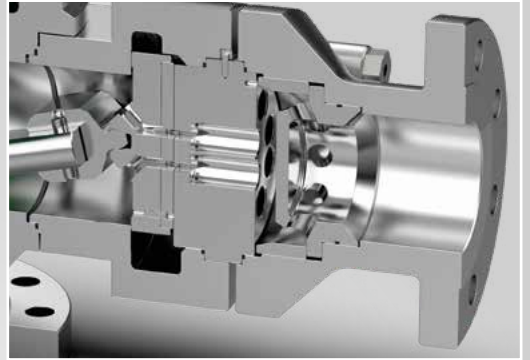

SSV 40-50 with throttle in the bypass

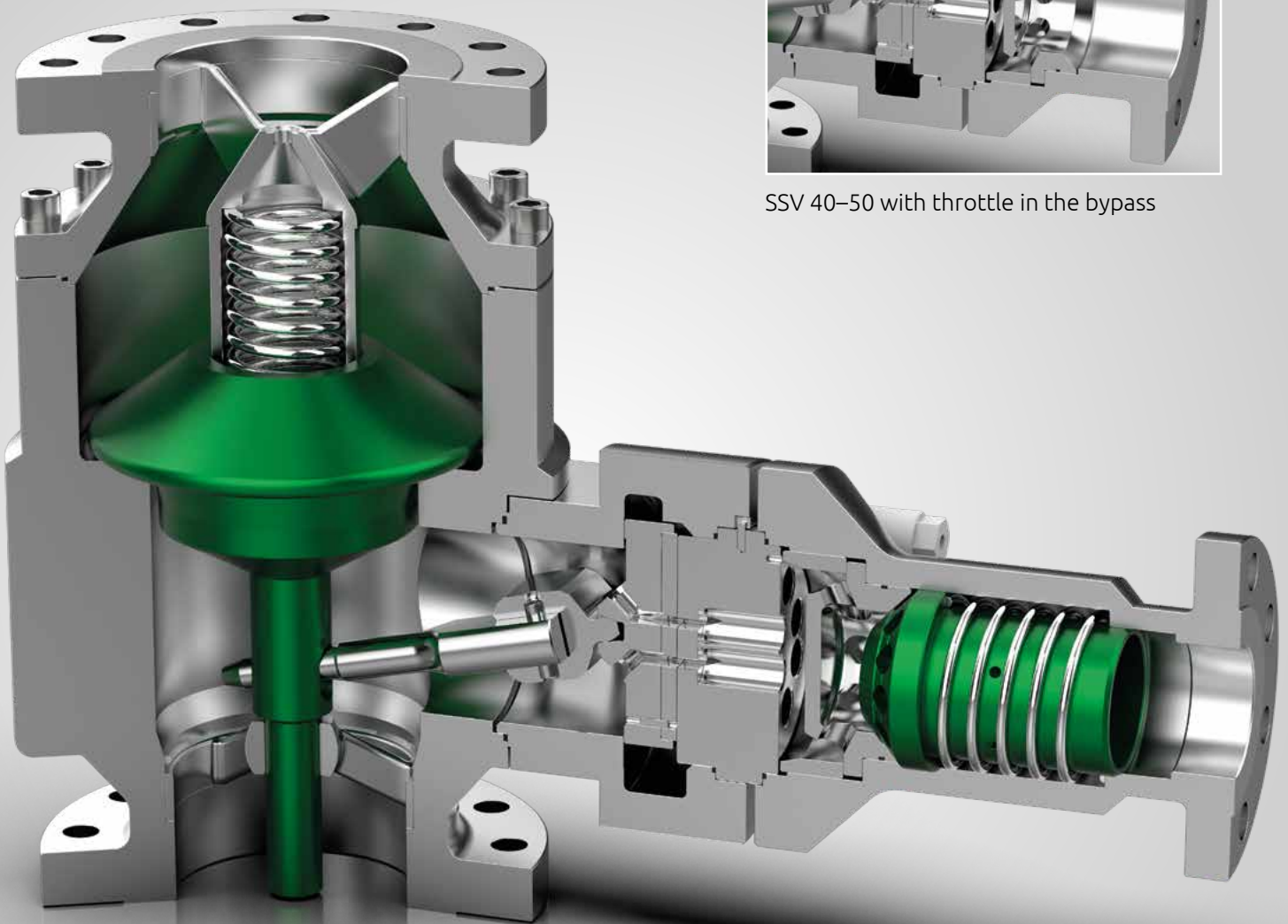

SSV 70-80 with non-return valve in the bypass

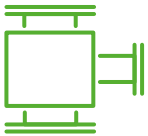

The AR Valve of our SSV series 40–80 is especially designed for centrifugal pumps which in relation to the main flow require a significantly increased demand for minimum flow, up to 70% of the main flow at low discharge pressure. Due to the design of the control disc, the use of the valves is limited to a maximum pressure difference between inlet (DN1) and bypass outlet (DN3) of 40 bar.



SIP Series

For intermediate pressures

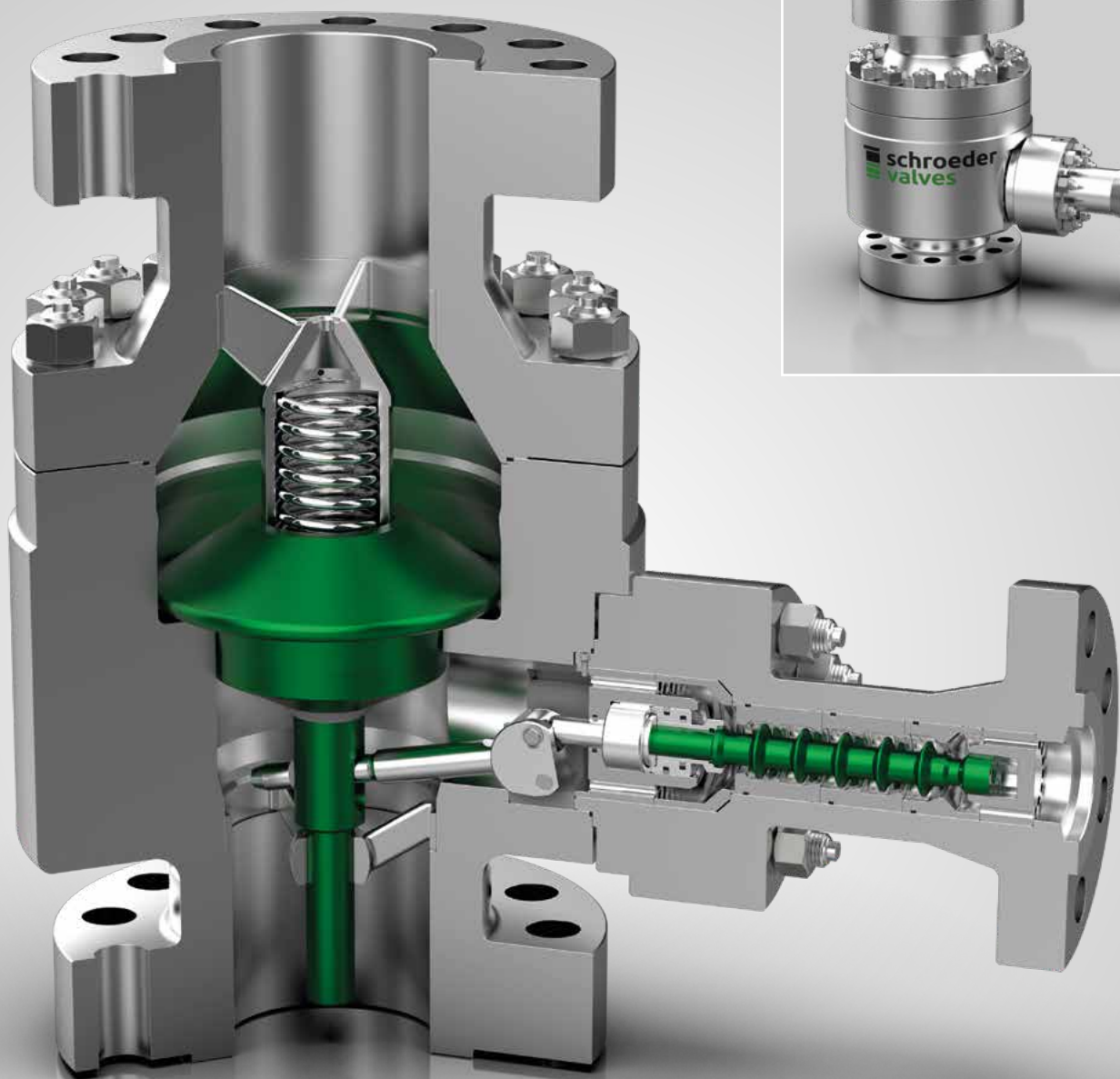

SIP 18/20

SIP 30/32

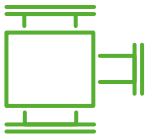

The AR Valve of our SIP series is a pump protection device particularly developed to cover applications up to 280 bar with frequent plant operation at minimum flow conditions with open bypass, i.e. split flow to process and bypass line.

Scope

The most relevant application for this valve type is the boiler feed water cycle of combined cycle power plants (CCPP). In these power plants the bfw-pumps operate frequently at minimum flow conditions with pressures of 60–280 bar. The reason is the technical concept of a CCPP – for example gas turbine cooling with bfw – as well as its purpose to cover load peaks or the natural load fluctuation of renewables in the energy grid.

Operating principle

The bypass of the SIP valve is controlled by a multistage piston providing a near cavitation-free operation at any time thanks to the multistage pressure reduction at all flow rates. The piston also ensures a modulating flow control from 100%–10 % bypass flow rate. An accelerated shut-off (1–2 sec.) at <10 % opening avoids most wear critical operation range. The wear-intensive extreme partial load range is deliberately overridden. The piston seat is separated from the pressure reduction and located at the high-pressure side. Thus, the shut-off function is optimally protected against cavitation attack. Even if cavitation would occur in the last throttle stages, the shut-off function would not be affected leaving the valve fully functional.

SIP 30/32 – Ready to Replace

The SIP 30/32 version has been specifically developed for fast and reliable replacement of competitor valves, e.g. Schroedahl TDM, with comparable bypass technology, only better. Exact competitor dimensions allow a true 1:1 replacement without piping modifications or plant adaptations. Beyond dimensional compatibility, the SIP 30/32 offers significant technological advantages. The bypass trim design positions the seat already within the first pressure reduction stage, providing enhanced protection against cavitation and wear. As all SIP valves, an accelerated bypass shut-off minimizes operation in wear-critical conditions, while the integrated hydraulic/mechanical non-return function in the bypass ensures reliable protection of the pump system at all times. The result: simplified replacement, improved operational reliability and extended service life.

Advantages at a glance

- accelerated shut-off to avoid cavitation by critical operation
 - integrated non-return function in the bypass
-

For intermediate pressures

SIP Dimensional drawing*:
main spare- and wear parts.

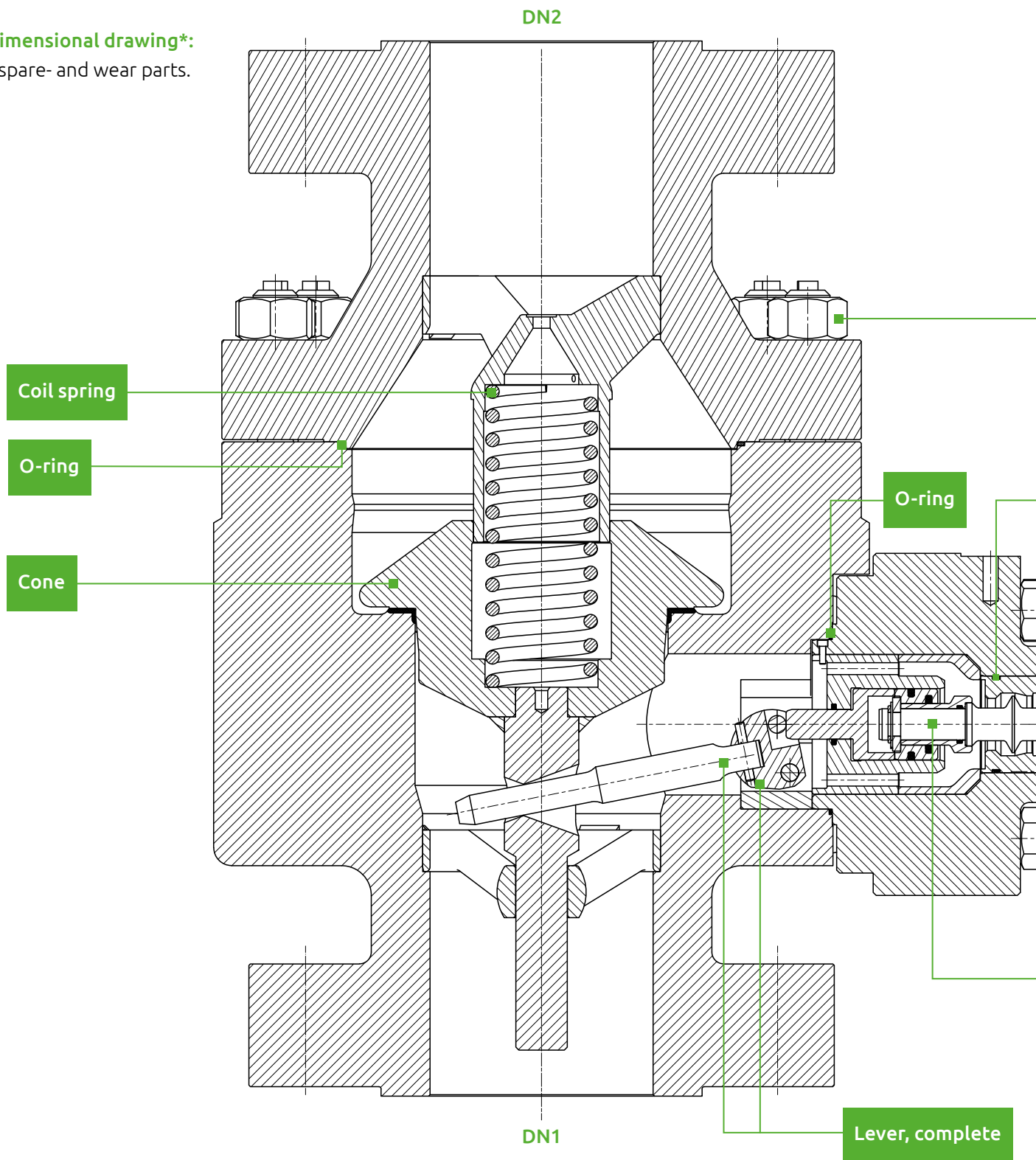

* also available with DN4 branch with functions as for the SSV series (page 14)

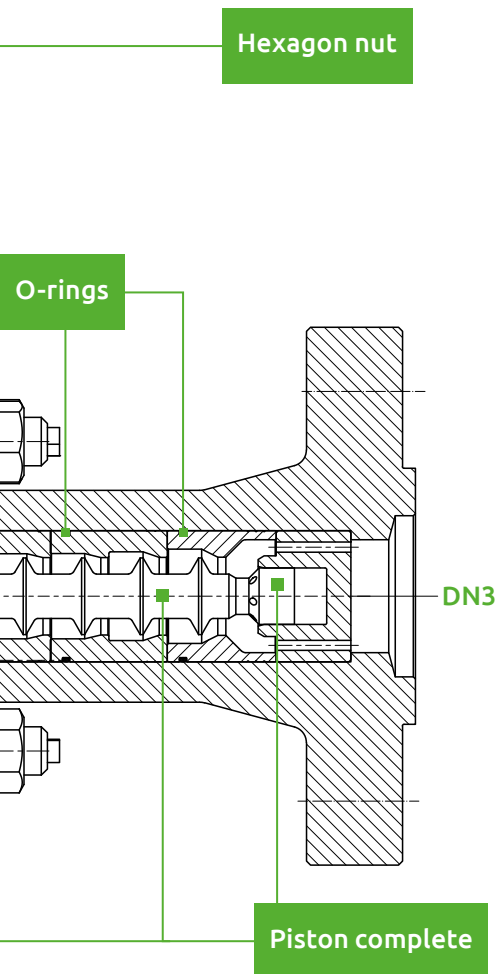

Combined Cycle Power Plant (CCPP) in Pray, Malaysia (at night)



Combined Cycle Power Plant (CCPP) in Beni Suef, Egypt

For high pressures

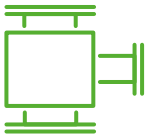

The AR Valve of our SHP series was developed for high and extremely high pressures beyond 250 bar and also works reliably under highly fluctuating load conditions.

Scope

Generally, the SHP valve applies to similar fields of services as the SIP type. Applications with frequent plant operation at minimum flow conditions with partially open bypass, i. e. split flow to process and bypass line. But due to its pilot operated powerful actuating system it is not restricted to discharge pressures below 250 bar. It can easily handle discharge pressures above 500 bar. Thus, it is also suitable for related injection services in the offshore market or high efficiency coal fired plants.

Operating principle

The bypass of the SHP valve is controlled by a multistage piston providing a near cavitation-free operation at any time thanks to the multistage pressure reduction at all flow rates. The piston also ensures a modulating flow control from 100%–10% bypass flow rate. An accelerated shut-off (1–2 sec.) at <10% opening avoids most wear critical operation range. The wear-intensive extreme partial load range is deliberately overridden. The piston seat is separated from the pressure reduction and located at the high-pressure side. Thus, the shut-off function is optimally protected against cavitation attack. Even if cavitation would occur in the last throttle stages, the shut-off function would not be affected leaving the valve fully functional.

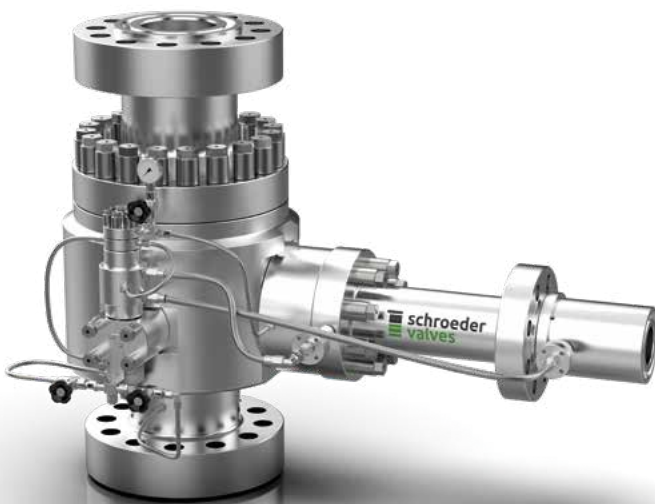

Advantages at a glance

- fully automatic minimum flow control system
 - shut-off and pressure reduction are separate from each other
 - SHP 18/20 with non-return valve in the bypass
-

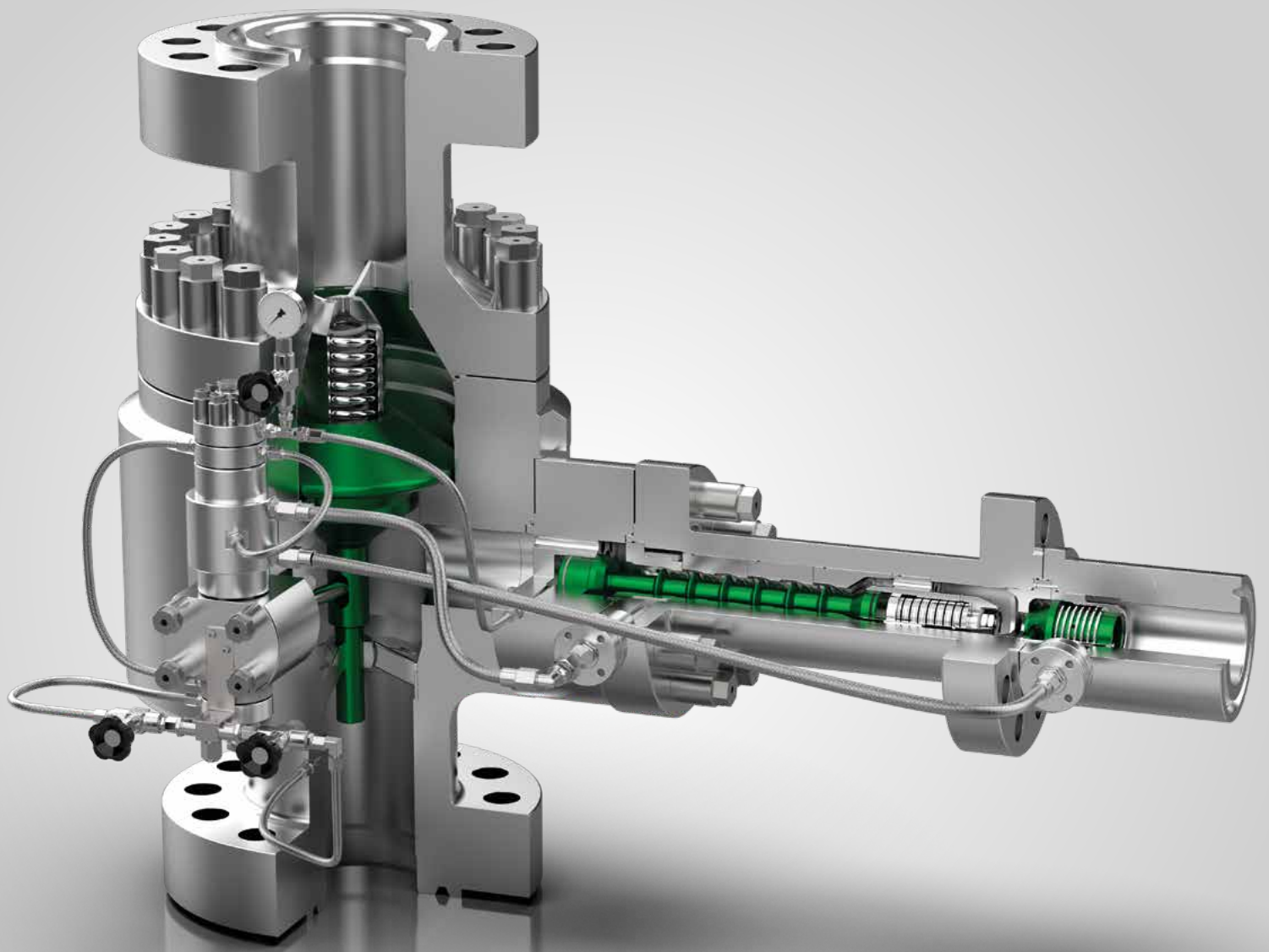

SHP 18

SMA Series

High pressure ON or OFF

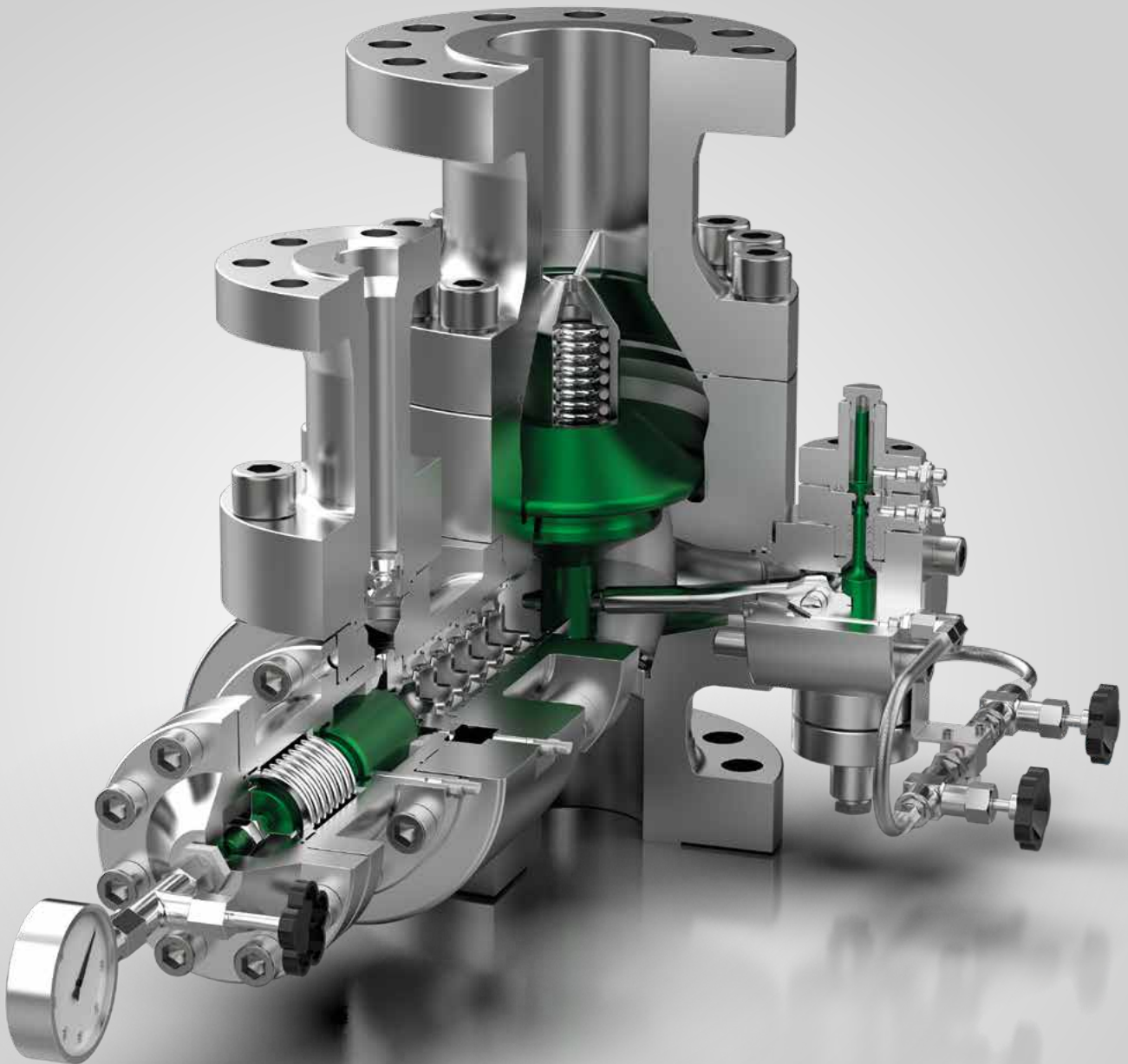

SMA 64

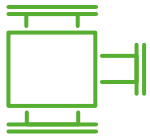

The SMA automatic minimum flow system is an AR Valve that offers low wear and very high operational safety at the highest pressure loads.

Scope

The properties of the SMA automatic minimum flow system make it the ideal valve for the protection of pumps in steel mills (descaling applications), but also for power plants or injection service in on-/offshore applications.

Operating principle

The SMA valve is equipped with an ON/OFF function: The recirculation flow is controlled by means of a piston, which is either in fully open or fully closed position. This ON/OFF-characteristic of the bypass has a switching time of

max. 2 seconds. The pressure breakdown in the bypass is done by a multistage throttling system. As soon as the main pump flow falls below a predetermined value, the valve opens the bypass and safely drains the minimum volume, even if the pumping volume in the main flow direction drops to zero. The bypass is always completely opened or closed through its pilot-controlled valve piston. This ON/OFF control makes it possible to increase the previous load limit of the valves from 200 bar to > 500 bar discharge pressure. The preferred utilization range is thus between PN 250 and PN 400 or ASME CLASS 2500. The bypass amount may be up to 35 % of the main pumping volume.



Advantages at a glance

- pressure break-down in the bypass by multistage throttles
 - pilot valve operated bypass allows for low pressure loss in main line
 - very low wear of pressure reducing parts
-

The smartline valve

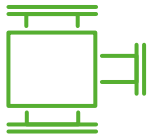

The SML Series is an Automatic Recirculation Valve engineered in Germany and manufactured at our factory in India. Under constant supervision and following the Schroeder Valves quality standards, the smartline valve for low-pressure applications is supplied to you directly from Pune, Maharashtra.

The SML series is an Automatic Recirculation Valve designed to protect standard centrifugal pumps. It reliably prevents damage caused by dry running and low-flow operation, reducing wear and avoiding premature pump failure. The SML series is available in multiple sizes for low-pressure applications and is suitable for a wide range of media with operating temperatures from -50°C to 200°C .

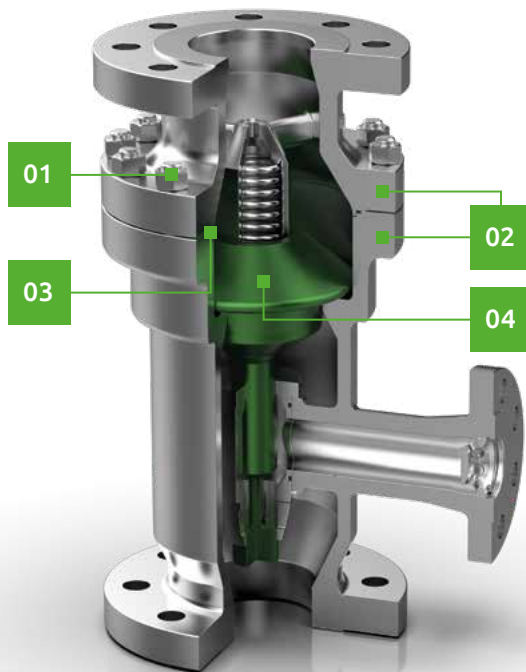

- 01 Bolts/Nuts
- 02 Pressure retaining parts SS
- 03 O-Ring
- 04 Internal parts SS

The SML 10/18 series combines a smart and compact valve design with an excellent price-performance ratio. Developed for standard pump protection applications, the smartline concept focuses on operational reliability, simplified integration and economic efficiency. Exact competitor dimensions, e.g. Schroedahl SUL, enable straightforward 1:1 replacement without modifications to existing piping or plant layout. The result is a cost-effective upgrade path combined with proven Schroeder Valves quality and engineering expertise.

Sizing and Selection

$$K_v = Q_{By} * \sqrt{SG / \Delta P} \quad C_v = 1.1561 * K_v$$

- Q_{By}: Required Bypass Flow Rate [m³/h]
- SG: Specific Gravity
- Δp: Differential Pressure [Bar]
- K_v: Flow Coefficient [m³/h]
- C_v: Flow Coefficient [USgpm]

Example:

- Medium: Cooling Water – SG = 0.992
- Nominal Main Flow Rate (Q₁₀₀) = 153 m³/h
- Required Min. Flow Rate (Q_{By}) = 62 m³/h
- Differential Pressure (ΔP) = 32 bar

Calculation:

$$K_v = 62 * \sqrt{\frac{0.992}{32}} = 10.92 \text{ m}^3/\text{h}$$

Dimensions and Weights

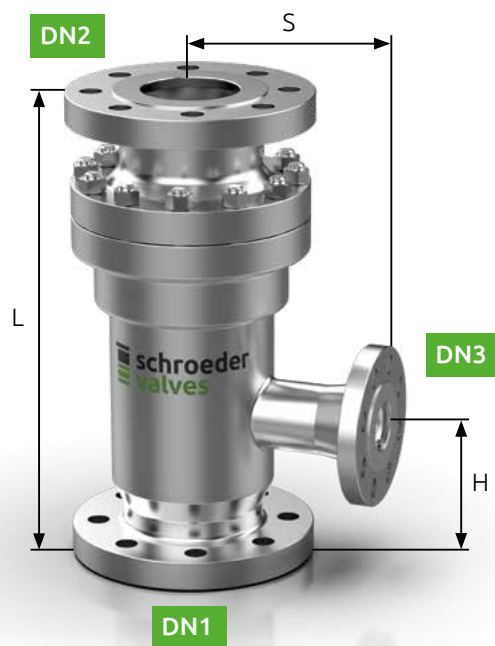

Flanges acc. to ASME B16.5

Size	2"	3"	4"	6"	8"	10"
DN 1/2	2"	3"	4"	6"	8"	10"
DN 3	1"	1.5"	2"	3"	4"	4"
L [mm]	305	406	495	679	902	902
H [mm]	108	136	159	228	305	305
S [mm]	130	165	209	267	356	356

Weight [kg]

150 RF	20	37	78	150	428	445
300 RF	25	44	81	176	454	486

Larger sizes upon request

Features and Functions

- Valve size: 2"–10" (larger upon request)
- Valve rating: Class 150/300
- Connection flanges: ASME B16.5 RF and EN 1092-1
- Cast housing: CF8M stainless steel
- 2-piece body design
- Internal parts: Stainless steel
- Bypass: Delta P_{max} ≤ 40 bar
- Suitable for a large range of different media
- Admissible medium temperatures from –50 °C to 200 °C
- Sizing and selection according to defined and fixed staggered design-matrix for body and internal parts
- Automatic bypass flow control with modulating function
- Orifice plate, if required, only up to 20 bar delta_p in the bypass
- Check valve function for main flow
- Non-return function in the bypass branch upon request
- Stop wasting energy through continuous bypass flow, save energy with smartline!

 engineered in germany

 made in india

Back pressure device

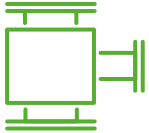

The back pressure device SDV prevents the static pressure in the upstream piping system to fall below a defined minimum value – irrespective of the flow rate.

That means the specified minimum pressure is maintained, from the nominal flow rate to zero flow. Back pressure devices are mainly used to avoid cavitation and partial evaporation in the fluid. By increasing the pressure level, they prevent the static pressure to fall below the local vapor pressure. The SDV has an integrated non-return function, i.e. the system is also protected against reverse flow. Size and pressure rating of the SDV are usually guided by the bypass of the AR Valve. It is available in all standard materials, sizes and pressure classes and suitable for all fluids that apply also to the AR Valve.

Advantages at a glance

- no evaporation and cavitation for smooth operation
 - definition of a back-pressure in the bypass line
-

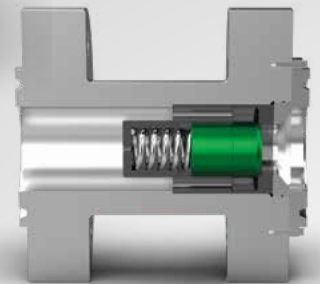

SDV 2: Design type with connecting flanges

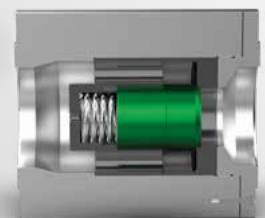

SDV 4: "Sandwich" design type without flanges

SSD Series

Multi-port throttles



SSD 1: Multi-stage throttle set with butt weld end

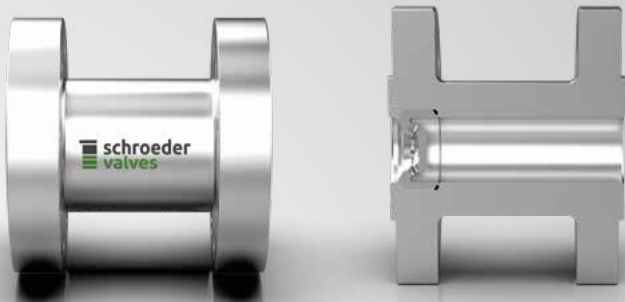

SSD 2: Multi-stage throttle set with fixed throttles (one or more stages)

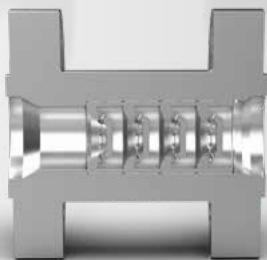

SSD 3: Multi-stage throttle set with removable throttles



SSD 6: Multi-port throttle disk

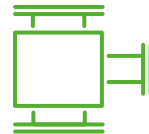

The multiport throttles SSD 1–6 are used in nominal widths ranging from DN20 to DN500 (0,5"–20"), in standard pressure steps up to PN630 (ASME CLASS 4500) and up to a permissible media temperature of 400°C.

The throttle housings are normally made of carbon steel suitable for pressurized vessels, but can also be made of various types of stainless steel or alloys, depending on the medium.



Customer Service

Quality products should be accompanied by excellent service, which is why Customer Service has always been a central pillar of our culture. Schroeder Valves is known for comprehensive support and fast response concerning both the procurement process as well as maintenance and repairs. We offer a self-contained package – from advice in the product right up to the documentation.

With comprehensive Sales and Service support we make sure that you find an expert in each region, who will find the best solution to protect your pumps or to maintain your installed equipment. To ensure 100 % quality, we have implemented a worldwide unique test center. Prior to leaving our factory, each valve is hydraulically tested to ensure and document the highest degree of quality and functionality.

We stand by your side providing you

- original spare and wear parts
- as-built valves
- technical service and support (also on-site)
- a revision of your valve in our service center

Spare parts

In our premises in Germany we keep an important stock of all regular wear parts like springs, O-rings as well as diverse sealings and screws. Original tailor-made parts like bypass internals, cones or complete valve branches are manufactured per order for the specific valve. To guarantee for a supply of the correct parts, each valve is identified by a 5-digits serial number that can be found on the valve's name plate. This number shall always be indicated in every communication. Our experienced CS-staff will assist you to select the required parts or guide you in terms of preventive maintenance. Parts

can be identified using the IOM and the contained pages with the valve dimensional drawing and bill of materials.

As-built valves

As-built valves are based on the original or last manufactured valve that is identified by its individual 5-digits serial number. Those valves are 100 % copies in material, size and pressure rating, as well as in the design of all internal parts. Therefore, it is assumed that the pump process data, for those the original valve was designed, remain identical. If process data changes have occurred, you should inform us in order to consider those changes and confirm if the valve specification is applicable again.

Valve replacements

Schroeder Valves can be implemented in existing systems, replacing AR Valves from other manufacturers. Main dimensions and flange connections can be verified, internal designs are realized individually according to the pump process data.

✉ service@schroeder-valves.com

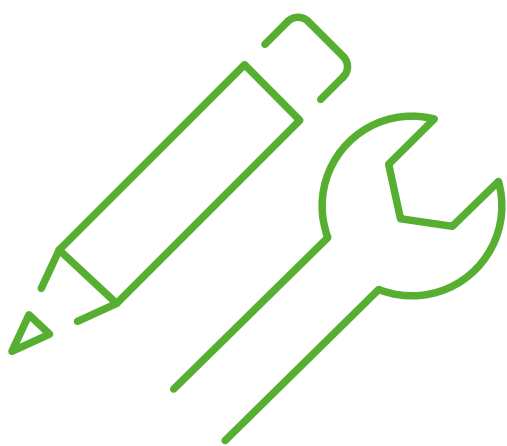

Customer service



Certifications, standards and regulations

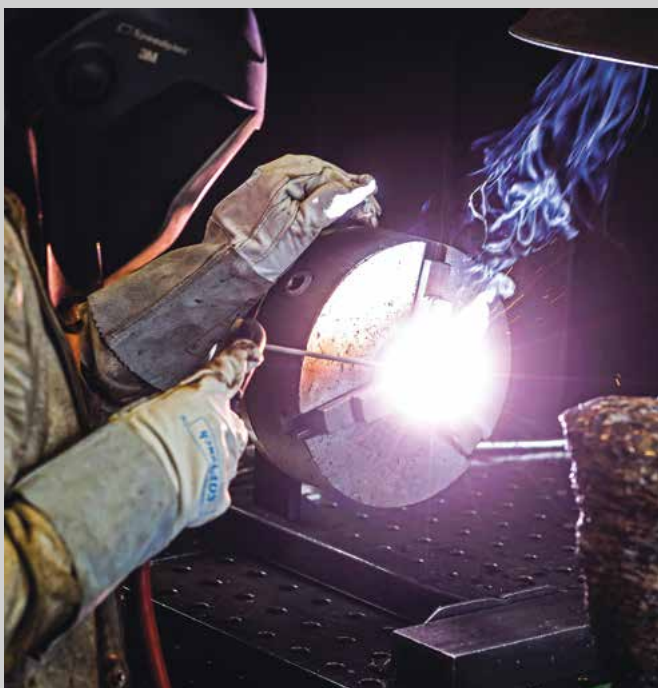

**Certifications, standards
and regulations**



Our automatic recirculation valves and multistage throttles are designed according to the AD 2000 regulations (e.g. strength calculation, materials that can be used, etc.). Our products are CE-labeled in accordance with Directive DGRL 2014/68/EU for pressurized vessels and a conformity statement is issued (except SML series made in India).

All hazard groups in categories 1 to 4 are included in the certification according to Module H1 of Directive DGRL 2014/68/EU. For all pressurized individual components of the valves and multistage throttles, all materials used have been certified in Category 3.1 acc. EN 10204 or higher.

The products may be accompanied by the following:

- Certificate of compliance for internal components without a construction test according to 2.1.
- Certificate of compliance for pressurized parts that have been subjected to a construction test and for which the execution of the pressure and functional test according to 2.2 has been confirmed.
- Acceptance test certificate for pressurized parts that have been subjected to a construction test according to 3.1 or 3.2.

We are certified for the Chinese market through TS and TSG licenses and for the Eurasian Economic Union through the TR CU 010/2011 and TR CU 032/2013 including EAC certification. Furthermore, we are certified as vendor for ADNOC and per KTA 1401 Nuclear Safety Standards Commission.

Painting specifications

Our own factory standard as well as special paintings are carried out in our own blasting cabinet and paintshop. Standard painting (C1) according to WN 40-SVC1 for carbon steel, high temperature painting -SVHT or, if required, even stainless steel painting -SVSS. In addition, special paintings as per ISO 12944-2 in corrosive categories C2–C5 are available upon request, just as other company standards.



Impressions





Schroeder Valves GmbH & Co. KG
Archimedesstraße 3
51647 Gummersbach · Germany

 +49 2261 50116-0

 info@schroeder-valves.com

 engineered in germany